



SISTEMA DE GESTIÓN DE COMBUSTIBLE



DISPENSADORES



KITS



BOMBAS



MEDIDORES



PISTOLAS

CUBE MC

CARACTERÍSTICAS

- GESTIÓN MULTIUSUARIO
- EQUIPO TODO EN UNO
- DISEÑO COMPACTO
- COMPATIBLE CON EL SOFTWARE SSM 2018
- FILTRO DE SUCCIÓN
- IP55

PIUSI CUBE MC es la versión mejorada del mundialmente famoso dispensador CUBE equipado con un panel electrónico capaz de gestionar hasta 120 usuarios y 255 transacciones. La robusta estructura incluye una bomba de paletas de cebado automático, válvula de derivación integrada, pistola automática y un soporte de pistola integrado con palanca de arranque y parada de la bomba.

RENDIMIENTO

HASTA
70 L/MIN

CAUDAL

CA/CC

TENSIÓN
ALIMENTACIÓN

± 0,5%

PRECISIÓN

HASTA
120

USARIOS



CUBE 70 MC



CUBE 70 MC CON PEDESTAL (OPTIONAL)

PACKAGING

CÓDIGO	PESO		PACKAGING			N. BOX / EUROPALET	
	KG	LBS	MM	PULGADAS	UDS./CAJA	✕	🚚
FO059400D	25	55	400X400X460	-	1	12	24
FO059413C	25	55	400X400X460	-	1	12	24
FO059414C	25	55	400X400X460	-	1	12	24
FO059415C	25	55	400X400X460	-	1	12	24
FO059422A	25	55	400X400X460	-	1	12	24



FILTRACIÓN



MONITOREO DE DEPOSITO



ENROLLADORES DE MANGUERA



ACCESORIOS



MATERIAL PROMOCIONAL



AIRE



ANTICONG.



AdBlue®



BIODIÉSEL



DIÉSEL



ALIMENTOS



GASOLINA



GRASA



QUEROSENO



ACEITE



AGUA



LIMPIAPARAB.

GRÁFICO

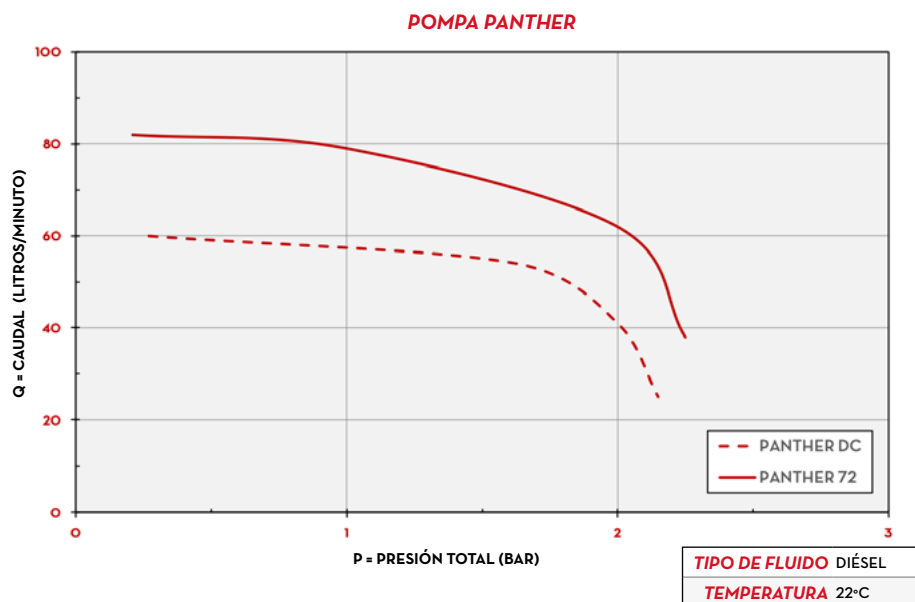

DIMENSIONES

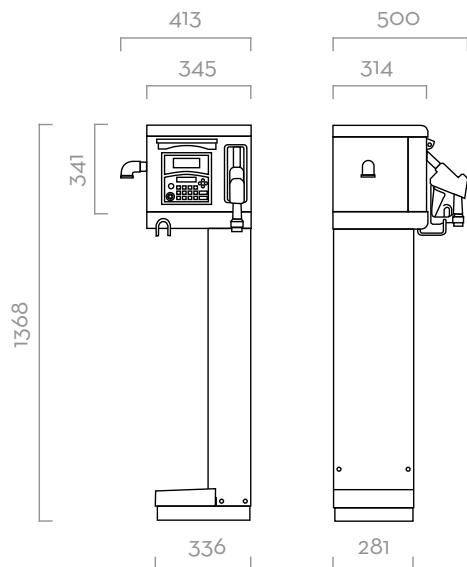

Las dimensiones se expresan en milímetros

CONTENIDO DE LA CAJA

- DISPENSADOR CUBE MC
- PISTOLA AUTOMÁTICA
- MANGUERA DE SUMINISTRO
- MANUAL DE INSTRUCCIONES

DETALLES



CUBIERTA DE PANTALLA



LLAVE DE CONDUCTOR (non incluida)



TRANSFERENCIA DE DATOS 2018 (pág. 44)



SOFTWARE SSM 2018 (pág. 44)

COMPONENTES

- **BOMBAS:**
 PANTHER AC PÁG. 102
 PANTHER DC PÁG. 114
- **MEDIDOR:**
 K600/3 PÁG. 134
- **PISTOLA:**
 PISTOLA AUTOMÁTICA PÁG. 158

FICHA TÉCNICA

CÓDIGO	DESCRIPCIÓN	TIPO DE FLUIDO	CAUDAL		TENSIÓN			BOMBA	MEDI-DOR	PISTOLA	FILTRO	ENTRADA	MANGUERA		PC		USERS
			L/MIN	GPM	V. CA /HZ V. CC	POTEN-CIA/ VATIOS	AMP. MÁX.						TIPO	TIPO	H2O FILTER	BSP	
FO059400D	CUBE 70 MC	D	70	18	230/50	900	4,2	PANTH 72	K600	A60	NO	1"	4M	1"	SÍ	50	
FO059413C	CUBE 70 MC DC 12V	D	56	15	12	300	35	PANTH DC	K600	A60	NO	1"	4M	1"	SÍ	50	
FO059414C	CUBE 70 MC DC 24V	D	70	18	24	420	25	PANTH DC	K600	A60	NO	1"	4M	1"	SÍ	50	
FO059415C	CUBE 70 MC 120 UT	D	70	18	230/50	550	3,3	PANTH 72	K600	A60	NO	1"	4M	1"	SÍ	120	
FO059422A	CUBE 70 MC 12V 120 UT	D	56	15	12	300	35	PANTH DC	K600	A60	NO	1"	4M	1"	SÍ	120	

SE PUEDE PEDIR CON DIFERENTE TENSIÓN Y 60 HZ DE FRECUENCIA