



SISTEMA DE GESTIÓN DE COMBUSTIBLE



DISPENSADORES



KITS



BOMBAS



MEDIDORES



PISTOLAS

SELF SERVICE FM 2.0

CARACTERÍSTICAS

- IDEAL PARA GESTIÓN DE COMBUSTIBLE
- INDICADOR DE NIVEL DE DEPÓSITO
- IMPRESORA DE TICKETS
- GESTIÓN MULTIUSUARIO
- ESTRUCTURA ROBUSTA
- FÁCIL MANTENIMIENTO
- BOMBA DE PALETAS DE GRAN CAPACIDAD
- SE REQUIERE EL SOFTWARE SSM 2.0
- IP55

PIUSI SELF SERVICE FM 2.0 es el dispensador de combustible todo en uno más alto de la gama, con conexión LAN integrada para garantizar una comunicación continua entre el dispensador y el PC, filtro water captor para garantizar la mayor pureza de los líquidos, indicador de nivel de depósito OCIO 2.0 y panel electrónico capaz de gestionar hasta 1000 usuarios y 650 transacciones. Compatible con el software SSM 2.0.

RENDIMIENTO

HASTA 90 L/MIN CAUDAL	FUNCIONAMIENTO CA CONTINUO ALIMENTACIÓN
± 0,5% PRECISIÓN	HASTA 1000 USARIOS



INTEGRADO TICKET PRINTER



SELF SERVICE FM 2.0

PACKAGING

CÓDIGO	PESO		PACKAGING			N. BOX / EUROPALLET	
	KG	LBS	MM	PULGADAS	UDS./CAJA	✕	

VERSIONES DE COLUMNA

FO074301A	75	165	1478X488X400	-	1	6*	4
-----------	----	-----	--------------	---	---	----	---



FILTRACIÓN



MONITOREO DE DEPOSITO



ENROLLADORES DE MANGUERA



ACCESORIOS



MATERIAL PROMOCIONAL



AIRE



ANTICONG.



AdBlue®



BIODIÉSEL



DIÉSEL



ALIMENTOS



GASOLINA



GRASA



QUEROSENO



ACEITE



AGUA



LIMPIAPARAB.

GRÁFICO

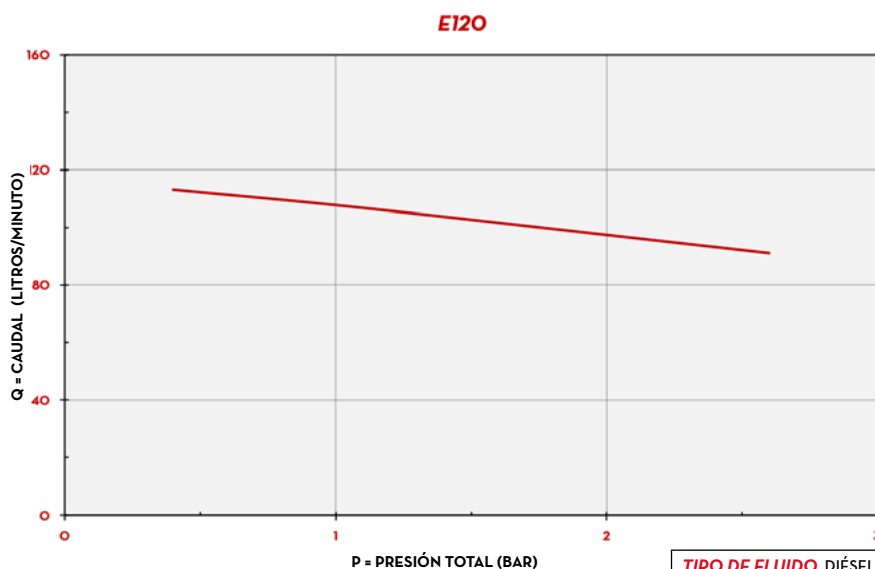

TIPO DE FLUIDO DIÉSEL

TEMPERATURA 13°C

DIMENSIONES

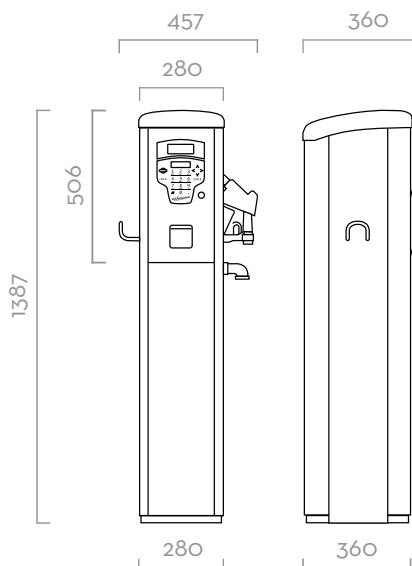

Las dimensiones se expresan en milímetros

CONTENIDO DE LA CAJA

- DISPENSADOR SELF SERVICE FM 2.0
- MANGUERA DE SUMINISTRO
- PISTOLA AUTOMÁTICA
- MANUAL DE INSTRUCCIONES

DETALLES



COMPONENTES

- **BOMBAS:**
E120 PÁG. 106
- **MEDIDOR:**
K600/3 PÁG. 134
- **PISTOLA:**
PISTOLA AUTOMÁTICA PÁG. 158
- **FILTRO:**
WATER CAPTOR PÁG. 170

FICHA TÉCNICA

CÓDIGO	DESCRIPCIÓN	TIPO DE FLUIDO	CAUDAL		TENSIÓN			BOMBA	MEDI-DOR	PISTOLA	FILTRO		ENTRA-DA	MAN-GUERA	SELF SERVICE MANAGEMENT 2.0
			L/MIN	GPM	V. CA /HZ	POTENCIA/ V. CC	WATIOS				AMP. MÁX.	H2O FILTER			

VERSIONES DE COLUMNA

FO074301A	SELF SERVICE 100 FM 2.0	D	90	24	230/50	1150	5,7	E120	K600	A120	SÍ	30µ	1" 1/2	4	NECESARIO
-----------	-------------------------	----------	----	----	--------	------	-----	------	------	------	----	-----	--------	---	-----------

SELF SERVICE FM 2.0