



SISTEMA DE GESTIÓN DE COMBUSTIBLE



DISPENSADORES



KITS



BOMBAS



MEDIDORES



PISTOLAS

ST 200 DC

CARACTERÍSTICAS

- ESTRUCTURA ROBUSTA
- DISEÑO COMPACTO
- LISTO PARA TRABAJAR
- ELEVADA FIABILIDAD
- USO INTENSIVO

PIUSI ST 200 DC es una unidad dispensadora portátil de 24 V para aplicaciones de gran caudal. El reducido peso de la unidad facilita su manipulación y la hace idónea para operaciones en ubicaciones de todo tipo, tanto para aplicaciones móviles como con tanques. Gracias a su medidor mecánico K700, este robusto dispensador garantiza la máxima precisión (bajo pedido).

RENDIMIENTO

HASTA

185 L/MIN

CAUDAL

24V

TENSIÓN

ALIMENTACIÓN

20 MIN

(40MIN APAGADO)

CICLO DE SERVICIO



ST 200 DC



PACKAGING

CÓDIGO	PESO		PACKAGING		
	KG	LBS	MM	PULGADAS	UDS./CAJA
FO0318000	18	40	480X370X265	18,9X14,6X10,4	1



FILTRACIÓN



MONITOREO DE DEPÓSITO



ENROLLADORES DE MANGUERA



ACCESORIOS



MATERIAL PROMOCIONAL



AIRE



ANTICONG.



AdBlue®



BIODIÉSEL



DIÉSEL



ALIMENTOS



GASOLINA



GRASA



QUEROSENO



ACEITE



AGUA



LIMPIAPARAB.

GRÁFICO

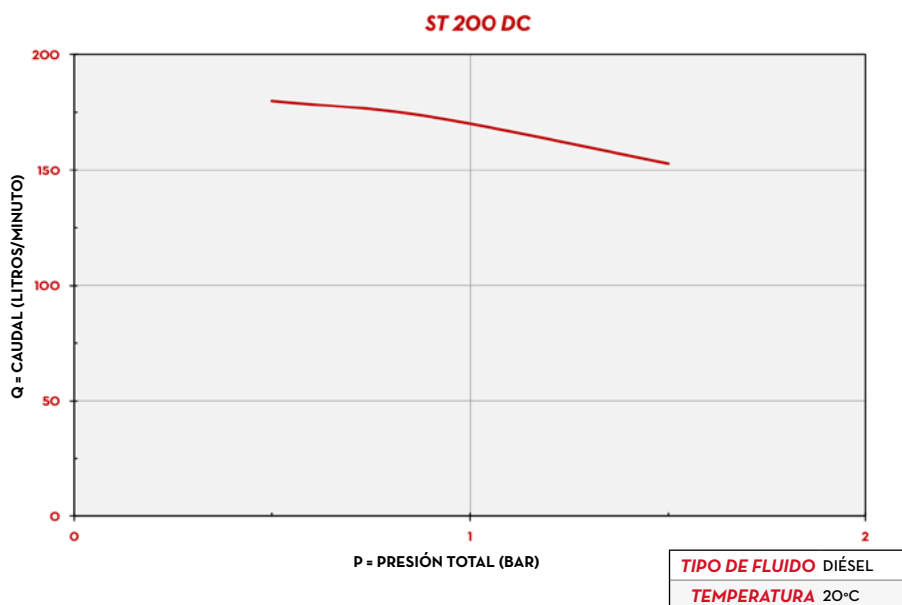

CONTENIDO DE LA CAJA

- UNIDAD ST 200 CC
- CABLE ELÉCTRICO CON PINZAS
- MANUAL DE INSTRUCCIONES

DETALLES



INTERRUPTOR ON/OFF



CABLE ELÉCTRICO CON PINZAS

DIMENSIONES

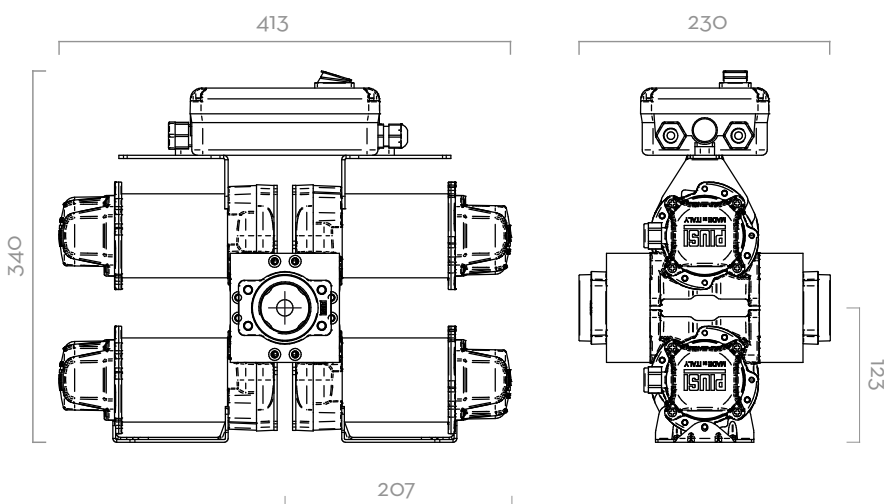

Las dimensiones se expresan en milímetros

MATERIALES

- CUERPO: HIERRO FUNDIDO
- ROTOR: ACERO SINTERIZADO
- PALETAS: RESINA ACETÁLICA
- JUNTA: NBR
- EJE: ACERO

FICHA TÉCNICA

CÓDIGO	DESCRIPCIÓN	TIPO DE FLUIDO	CAUDAL		TENSIÓN			CICLO DE SERVICIO MINUTO	BOMBA		PRESIÓN MÁXIMA BAR	SALIDA BSP
			L/MIN	GPM	V. CA / HZ V. CC	POTENCIA/ VATIOS	AMP. MÁX.		TIPO	Nº		
FO0318000	ST 200 DC 24 V	D	185	42-48	24	1200	50	30	BYPASS 3000	4	2	1" 1/2

ST200 DC